

PURCHASE CODES

APL 300/2 12/24V without thermo switch	3RL30212 / 3RL30224
APL 300/2 12/24V with thermo switch	3RL30212T247 / 3RL30224T247 3RL30212T260 / 3RL30224T260



SPARE PARTS

Thermo-switch 47-36 12V IP 67	1TRM47-36/12V
Thermo-switch 47-36 24V IP 67	1TRM47-36/24V
Thermo-switch 60-49 12V IP 67	1TRM60-49/12V
Thermo-switch 60-49 24V IP 67	1TRM60-49/24V
Cooling element	3RNL302
Frame	3CNL302.1
12VDC Electric fan	1VNAPL30012C
24VDC Electric fan	1VNAPL30024C

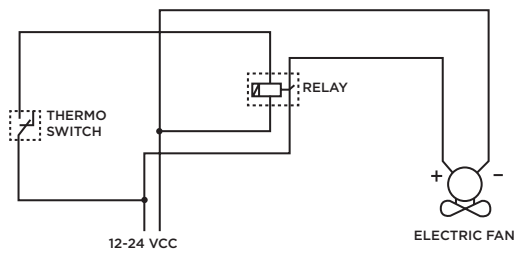
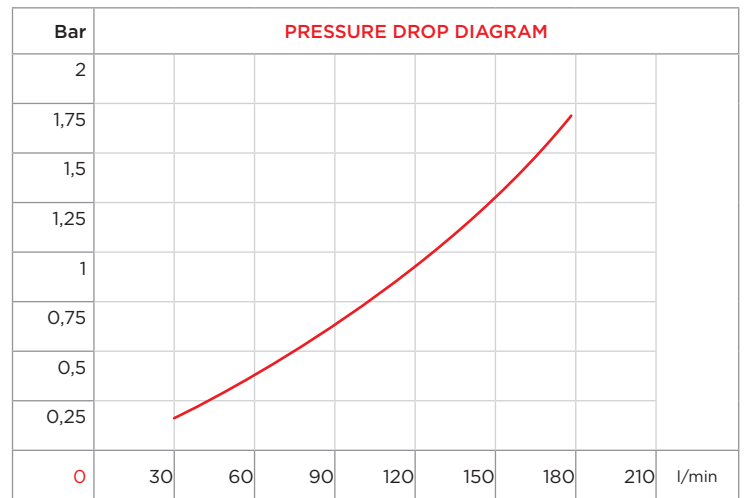
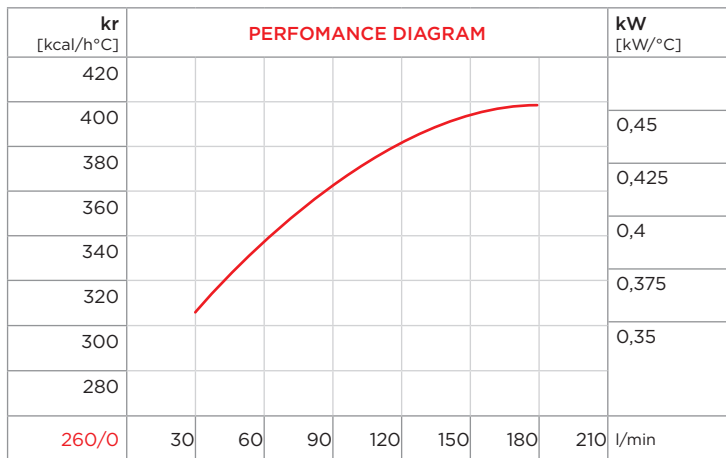

cSt	22	30	46	68	100	150	220
f	0,6	1	1,5	2,3	3,5	5	7

- Dimensions and technical characteristics are not binding

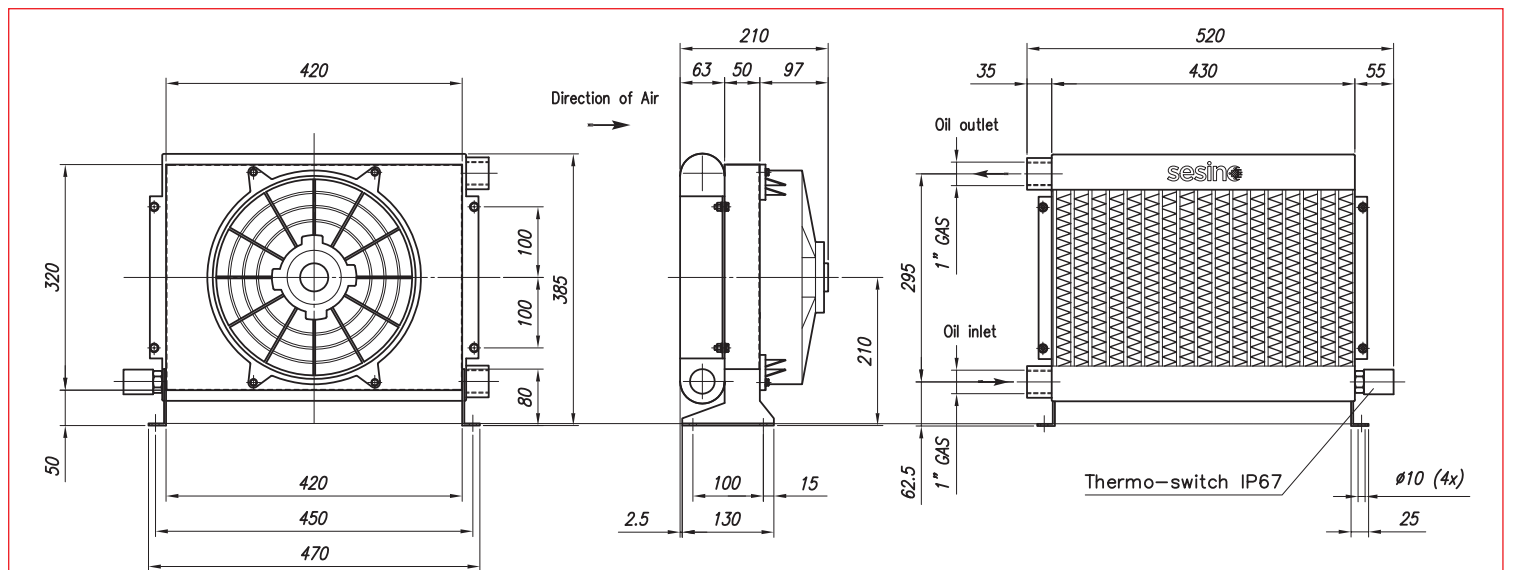

OIL FLOW	VOLTAGE	POWER	CURRENT	AIR FLOW	ELECTRIC PROTECTION	NOISE LEVEL	WEIGHT	CAPACITY	∅ FAN
l/min	V	W	A	m ³ /h	IP	dB(A)	kg	lt.	mm
30-180	12	180	15,0	2.200	68	83	14	3,6	280
30-180	24	180	7,5	2.200	68	83	14	3,6	280