

M18

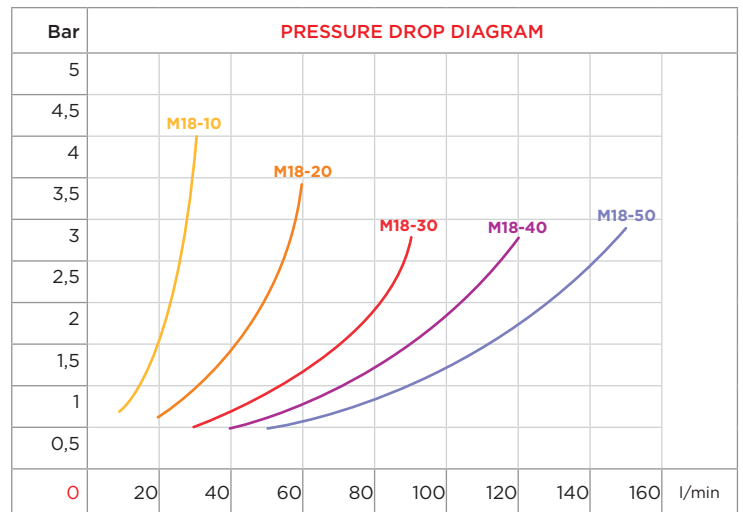
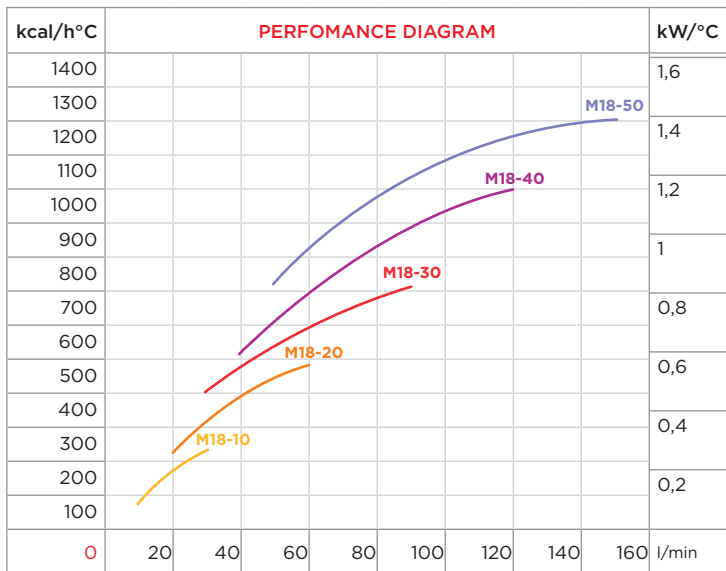
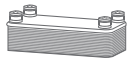

CORRECTION FACTOR

cSt	22	30	46	68	100	150	220
f	0,4	0,6	1	1,5	2,3	3,3	4,6

- Dimensions and technical characteristics are not binding

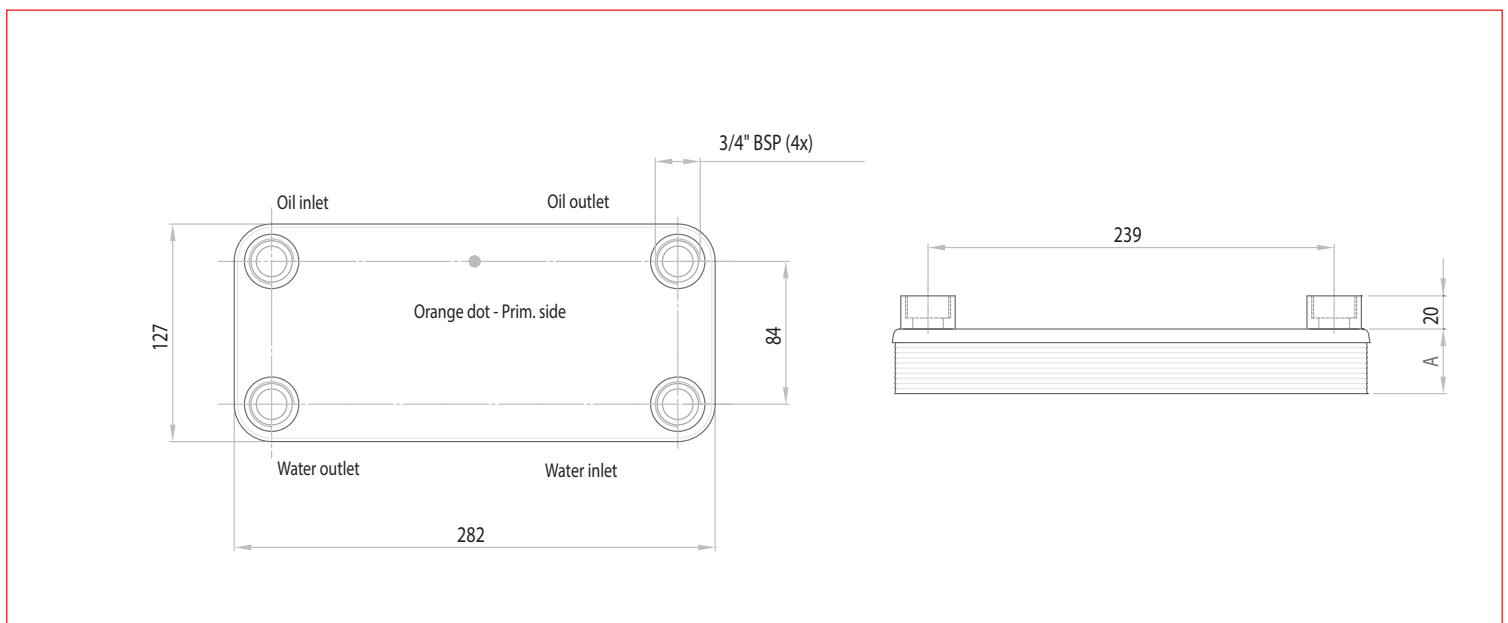

TYPE	SURFACE	OIL FLOW	COOLING CAPACITY	WEIGHT	DIMENSIONS
	m ²	l/min	kW/°C	kg	A
M18-10	0,195	10÷30	0,09÷0,27	2,5	28
M18-20	0,390	20÷60	0,25÷0,55	3,7	47
M18-30	0,585	30÷90	0,45÷0,83	4,8	66
M18-40	0,780	40÷120	0,60÷1,17	6,0	85
M18-50	0,975	50÷150	0,85÷1,40	7,2	104