



2. Shell and Tube Heat Exchangers

This leaflet describes heat exchangers which are intended for heating or cooling process fluids, they are for example suitable for closed circuit cooling of electrical equipment using demineralised water and for cooling water soluble oil solutions in quenching tanks.

The shell side usually contains the process fluid and the tube side water from the town mains or a cooling tower or an ethylene glycol solution from a chiller unit. In certain circumstances this flow arrangement can be reversed, but please consult us first.

The heat exchanger designation consists of a type number followed by a drawing number which is marked on the nameplate. This five figure drawing number alters according to duty and materials. Standard materials are cupro-nickel tubes, cast aluminium shell and cast iron end covers. In addition we have some heat exchangers with a copper alloy shell and others which also have bronze end covers. They are available with single or three pass end covers according to the duty. The single pass flow arrangement should be used when the tubeside flow is much larger than the shellside flow. Normally when the two flow rates are similar three pass flow on the tubeside will give best performance. To specify materials and configuration alter the five figure section of the designation as shown in Table 1.



Table1.

Standard Range Single Pass	Standard Range Three Pass	Bronze Shell Single Pass	Bronze Shell Three Pass	Bronze Shell & Bronze End Covers Three Pass
EC 80-1808-1 EC100-1808-2 EC120-1808-3 EC140-1808-4 EC160-1808-5	EC 80-1425-1 EC100-1425-2 EC120-1425-3 EC140-1425-4 EC160-1425-5	EC120-3805-3 EC160-3805-5	EC120-3345-3 EC160-3345-5	EC120-3645-3 EC160-3645-5
FC 80-2498-1 FC100-2498-2 FC120-2498-3 FC140-2498-4 FC160-2498-5	FC 80-1426-1 FC100-1426-2 FC120-1426-3 FC140-1426-4 FC160-1426-5	FC120-3806-3 FC160-3806-5	FC120-3346-3 FC160-3346-5	FC120-3646-3 FC160-3646-5
FG 80-3812-1 FG100-3812-2 FG120-3812-3 FG140-3812-4 FG160-3812-5	FG 80-1427-1 FG100-1427-2 FG120-1427-3 FG140-1427-4 FG160-1427-5	FG120-3807-3 FG160-3807-5	FG120-3347-3 FG160-3347-5	FG120-3647-3 FG160-3647-5
GL140-3508-2 GL180-3508-3 GL240-3508-4 GL320-3508-5 GL400-3508-6 GL480-3508-7	GL140-1428-2 GL180-1428-3 GL240-1428-4 GL320-1428-5 GL400-1428-6 GL480-1428-7	GL180-3808-3 GL240-3808-4	GL180-3348-3 GL240-3348-4	GL180-3648-3 GL240-3648-4
GK190-3509-3 GK250-3509-4 GK320-3509-5 GK400-3509-6 GK480-3509-7 GK600-3509-8	GK190-1658-3 GK250-1658-4 GK320-1658-5 GK400-1658-6 GK480-1658-7 GK600-1658-8			
JK190-3511-3 JK250-3511-4 JK320-3511-5 JK400-3511-6 JK480-3511-7 JK600-3511-8	JK190-1661-3 JK250-1661-4 JK320-1661-5 JK400-1661-6 JK480-1661-7 JK600-1661-8			
PK190-3510-3 PK250-3510-4 PK320-3510-5 PK400-3510-6 PK480-3510-7 PK600-3510-8	PK190-1669-3 PK250-1669-4 PK320-1669-5 PK400-1669-6 PK480-1669-7 PK600-1669-8			

EC RANGE

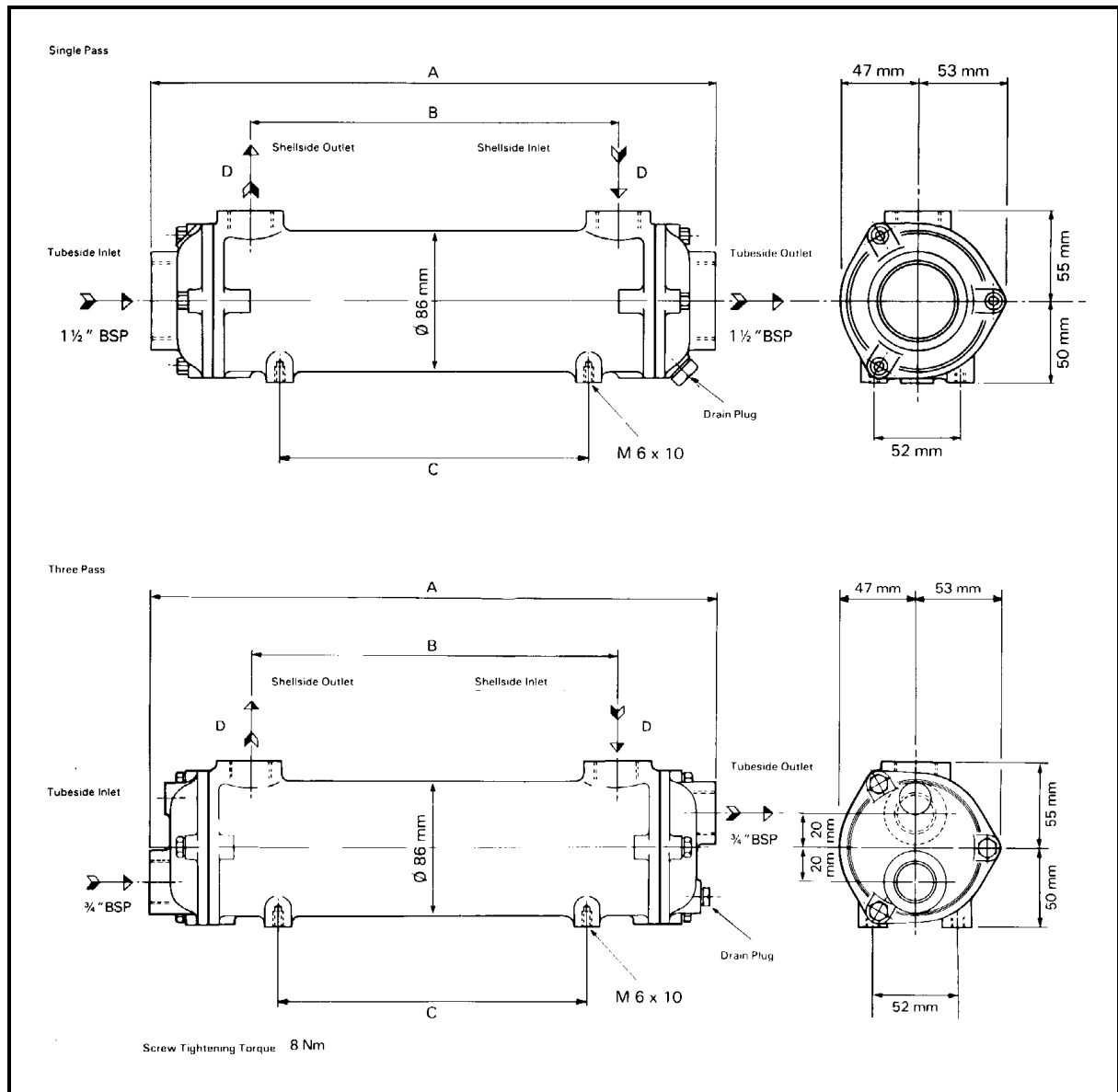

		A	B	C	D
	kg	mm	mm	mm	BSP
EC 80-	2.4	174	60	60	1/2"
EC100-	3.2	260	140	104	3/4"
EC120-	3.8	346	226	190	3/4"
EC140-	4.8	444	324	288	3/4"
EC160-	5.7	572	452	416	3/4"

Maximum working pressure 14 bar
 Maximum working temperature 100°C

FC RANGE

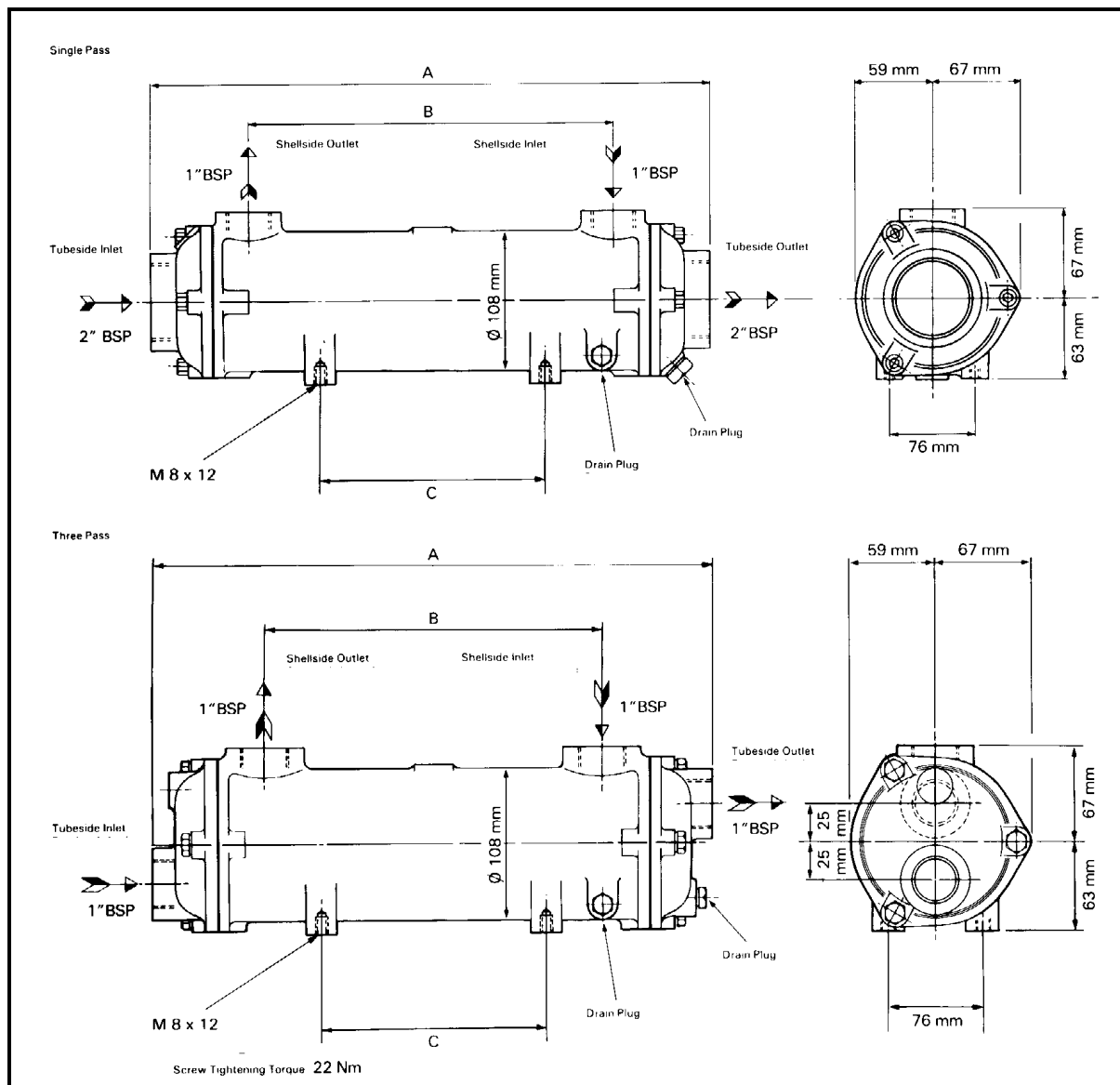

		A	B	C
	kg	mm	mm	mm
FC 80-	5.5	272	116	104
FC100-	6.3	358	202	190
FC120-	7.3	456	300	288
FC140-	9.4	584	428	288
FC160-	11.0	730	574	434

Maximum working pressure 14 bar
 Maximum working temperature 100°C

FG RANGE

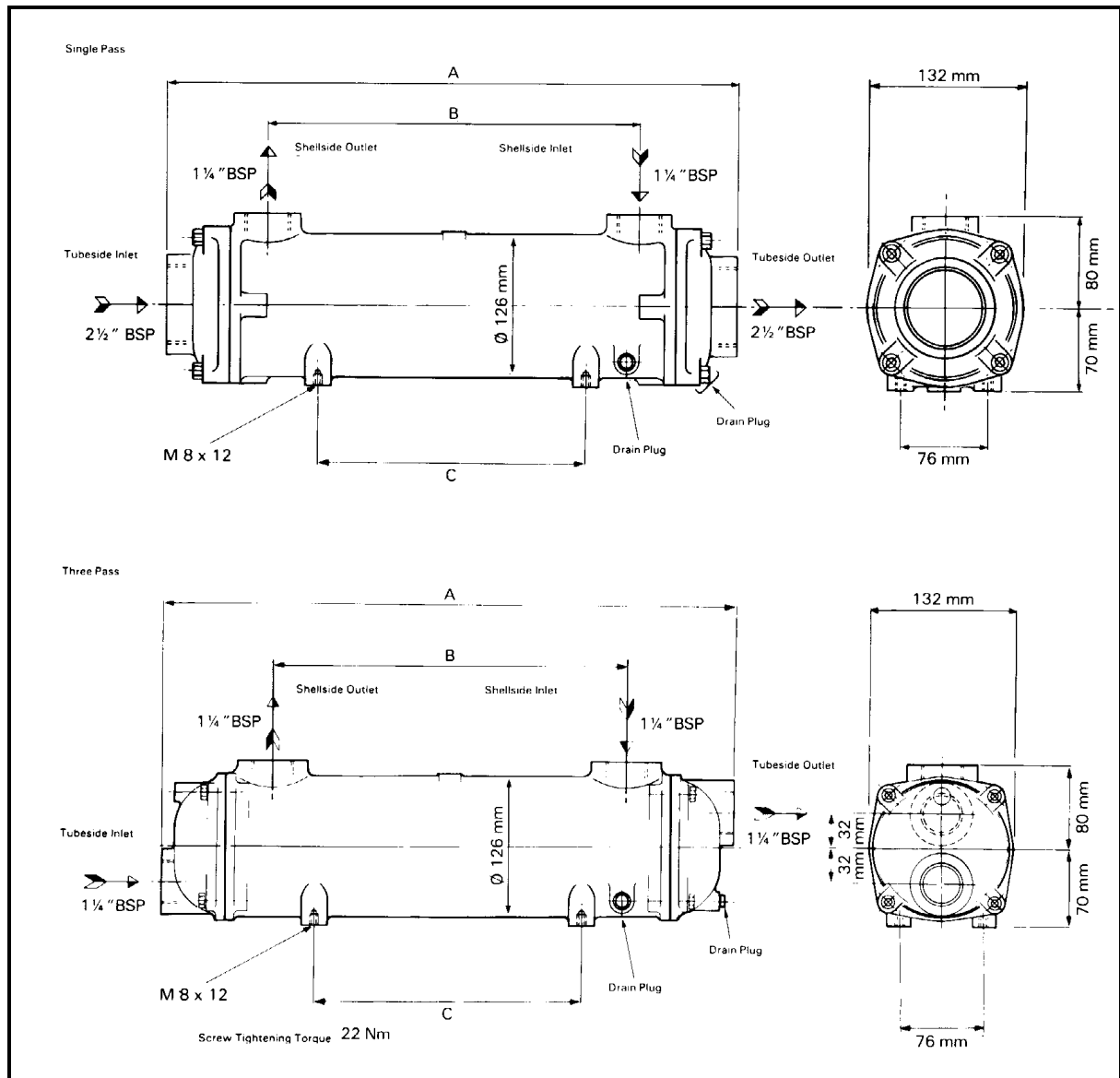

		A	B	C
	kg	mm	mm	mm
FG 80-	8.5	374	196	92
FG100-	10.0	472	294	190
FG120-	12.0	600	422	318
FG140-	14.5	746	568	464
FG160-	17.5	924	746	642

Maximum working pressure 14 bar
 Maximum working temperature 100°C

GL RANGE

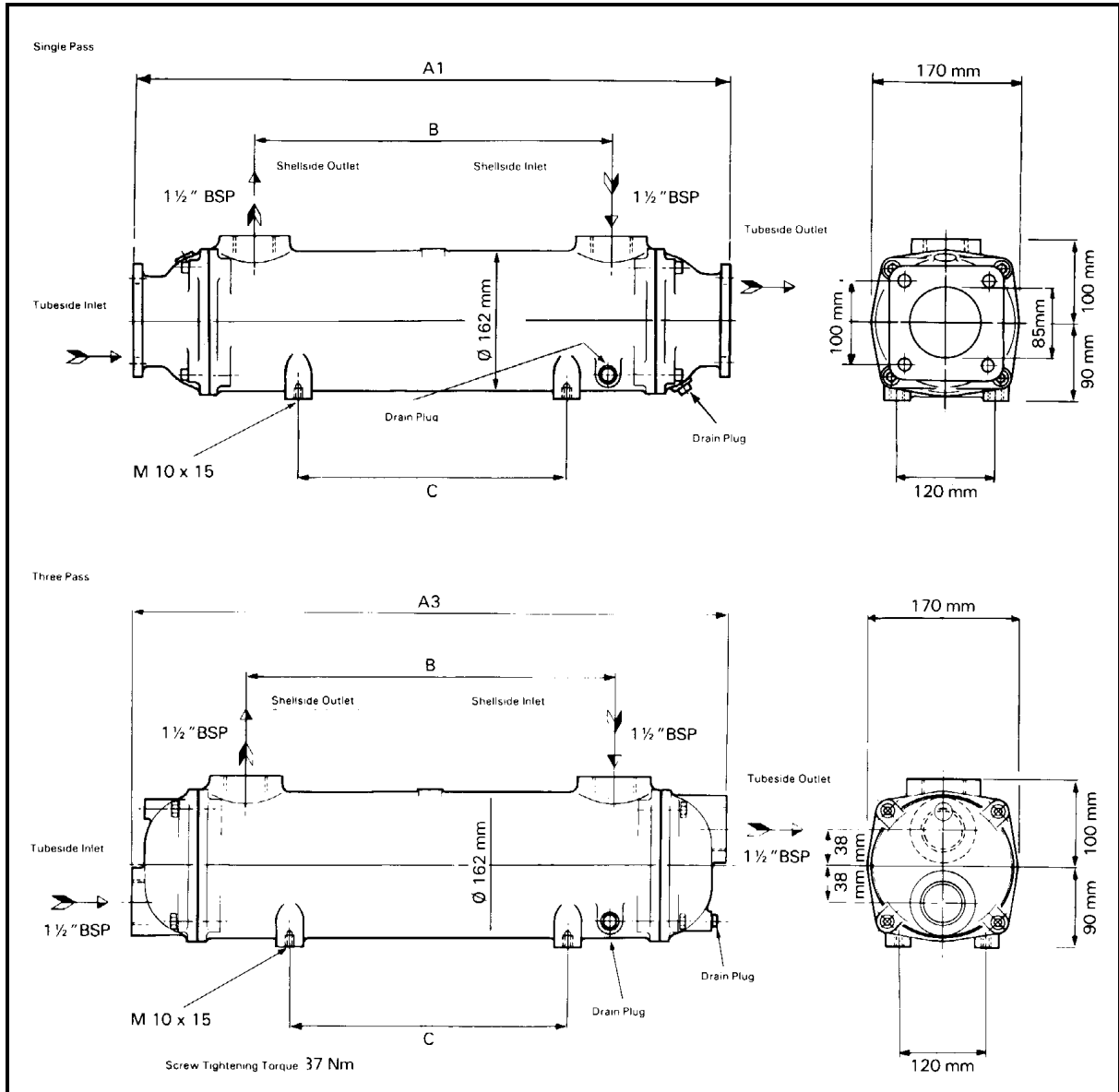

		A1	A3	B	C
	kg	mm	mm	mm	mm
GL140-	18	532	502	272	108
GL180-	21	660	630	400	236
GL240-	25	806	776	546	382
GL320-	30	984	954	724	560
GL400-	36	1186	1156	926	762
GL480-	42	1390	1360	1130	966

Maximum working pressure 14 bar

Maximum working temperature 100°C

GK RANGE

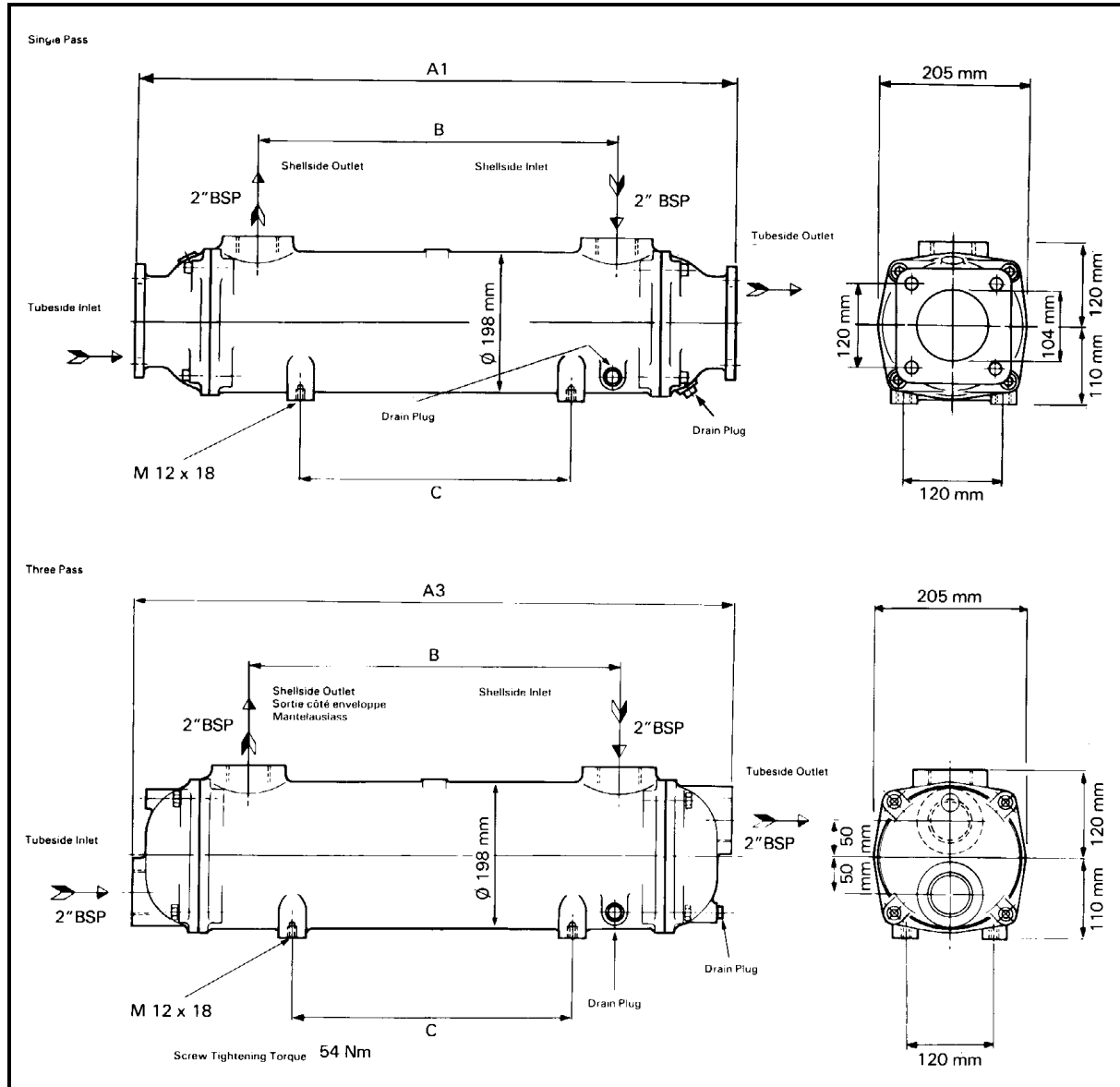

		A1	A3	B	C
	kg	mm	mm	mm	mm
GK190-	34	704	674	370	236
GK250-	39	850	820	516	382
GK320-	46	1028	998	694	560
GK400-	54	1230	1200	896	762
GK480-	62	1434	1404	1100	966
GK600-	74	1738	1708	1404	1270

Maximum working pressure 14 bar
 Maximum working temperature 100°C

JK RANGE

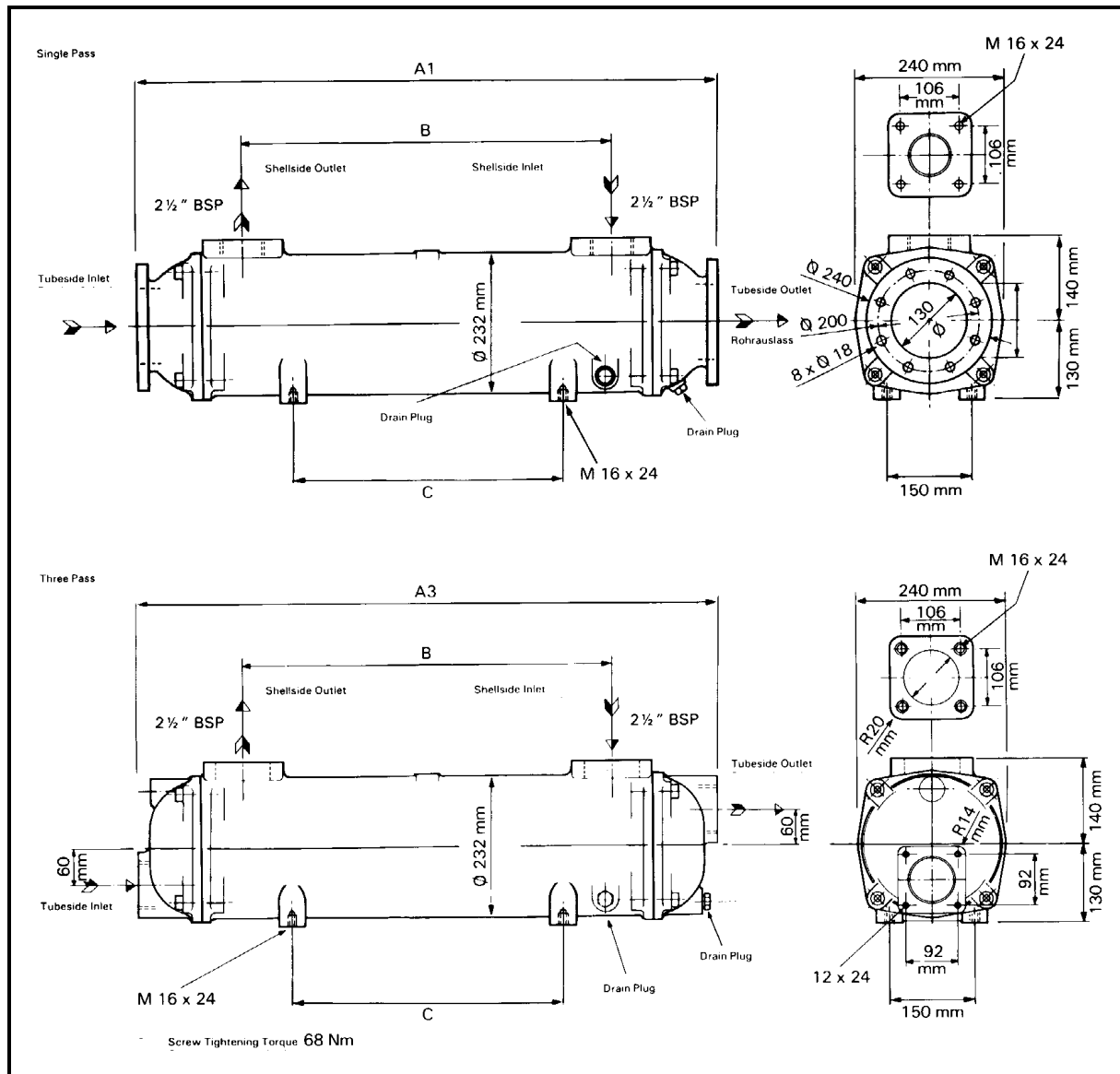

		A1	A3	B	C
	kg	mm	mm	mm	mm
JK190-	58	724	704	340	236
JK250-	66	870	850	486	382
JK320-	78	1048	1028	664	560
JK400-	92	1250	1230	866	762
JK480-	105	1454	1434	1070	966
JK600-	126	1758	1738	1374	1270

Maximum working pressure 14 bar
 Maximum working temperature 100°C

PK RANGE

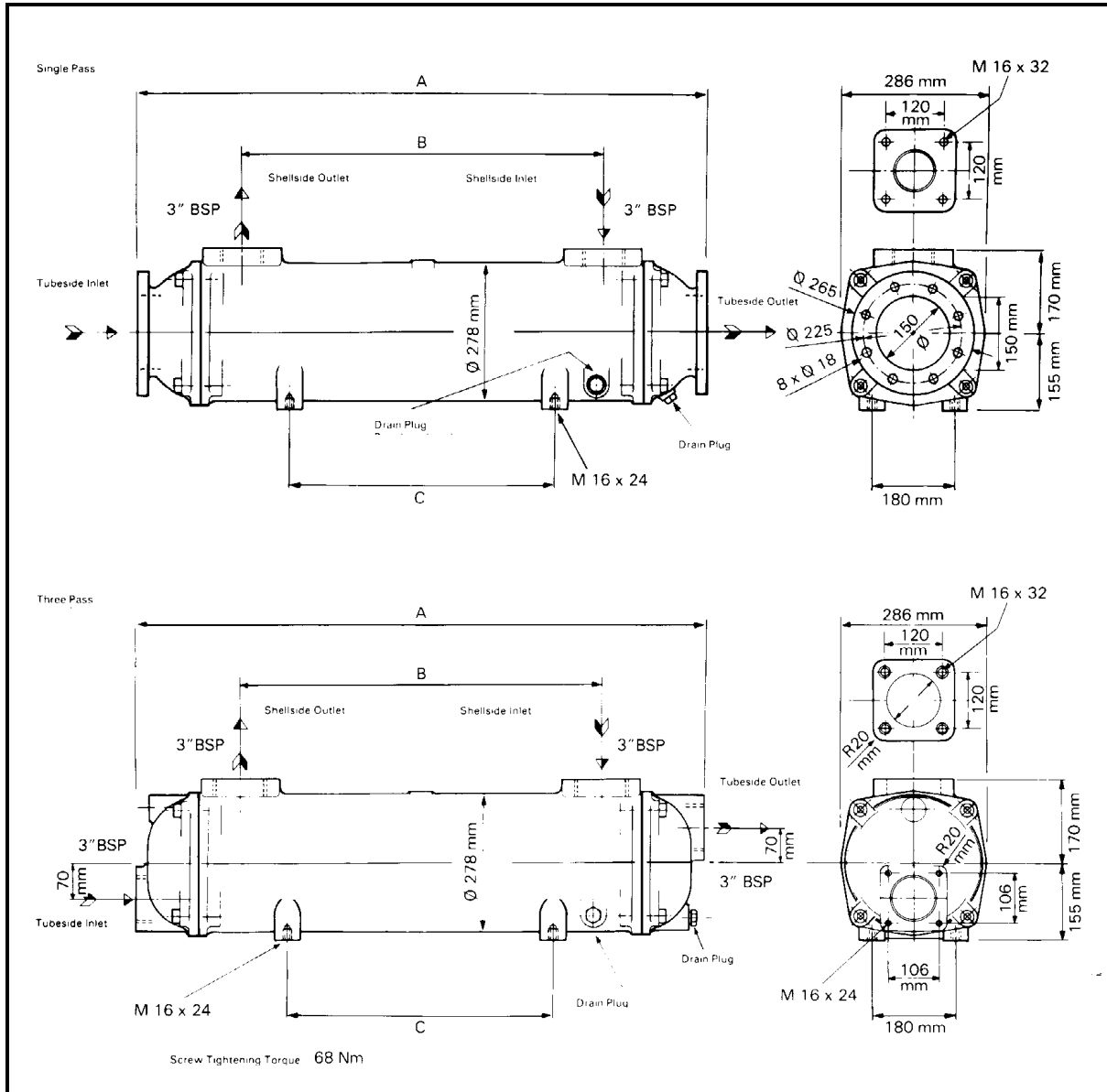

		A	B	C
	kg	mm	mm	mm
PK190-	81	754	330	236
PK250-	94	900	476	382
PK320-	110	1078	654	560
PK400-	125	1280	856	762
PK480-	140	1484	1060	966
PK600-	158	1788	1364	1270

Maximum working pressure 14 bar
 Maximum working temperature 100°C

INSTALLATION

SINGLE HEAT EXCHANGER

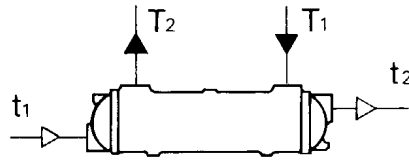

TWO HEAT EXCHANGERS IN SERIES END TO END

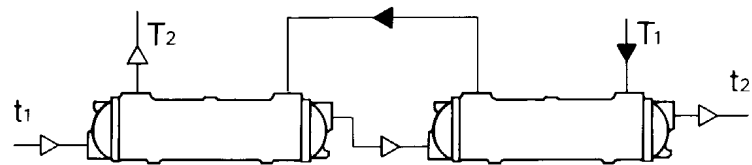

TWO HEAT EXCHANGERS IN SERIES SIDE BY SIDE

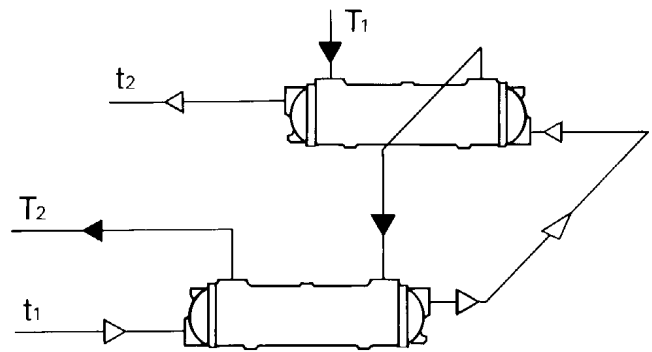

TWO HEAT EXCHANGERS IN PARALLEL

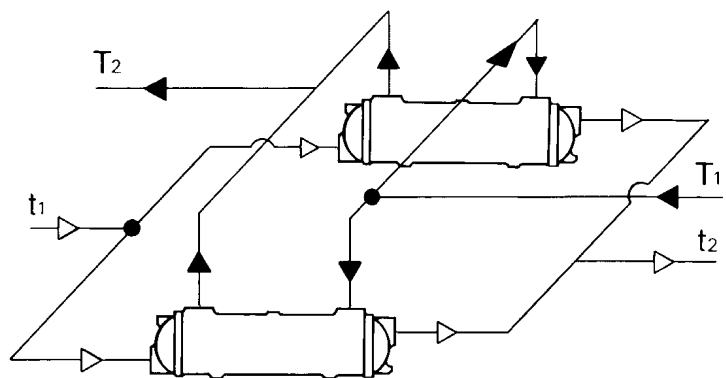

HEAT EXCHANGERS SHOULD ALWAYS BE CONNECTED FOR COUNTER-FLOW